

# OPERATING INSTRUCTIONS

## Manual Rotary Microtome TN 6000



**CE**

INS1000GB  
2019-030-004.00



# CONTENTS

<b>1. INTENDED USE</b>	.....	<b>4</b>
<b>2. SYMBOLS</b>	.....	<b>4</b>
<b>3. SAFETY NOTES</b>	.....	<b>4</b>
<b>4. COMPONENTS</b>	.....	<b>8</b>
<b>5. SPECIFICATIONS</b>	.....	<b>9</b>
<b>6. UNPACKING AND INSTALLATION</b>	.....	<b>10</b>
<b>7. OPERATION OF TN 6000</b>	.....	<b>11</b>
<b>8. CLEANING AND MAINTENANCE</b>	.....	<b>20</b>
<b>9. SERVICE</b>	.....	<b>21</b>
<b>10. OPTIONAL ACCESSORIES</b>	.....	<b>22</b>
<b>11. WARRANTY</b>	.....	<b>24</b>
<b>12. DISPOSAL</b>	.....	<b>24</b>

## 1. INTENDED USE

The rotary microtome TN 6000 is intended for cutting thin sections of soft paraffin-embedded and harder specimens for professional use in routine and research laboratories in the fields of biology, medicine and incovery.

The system of specimen advance operates very reliable from 0.5 to 60 µm. The quality of cutting of this microtome is increased by the automatic retraction during the upstroke of the specimen, which avoids rubbing on the disposable blades or microtome knives. This stops rapid deterioration of the disposable blade or microtome knife.

## 2. SYMBOLS



Dangers, warnings and cautions are marked by this symbol



Special instructions regarding the operation of the instrument are marked by this symbol



Mechanical components that can lead to injuries during operation are marked with this symbol.

## 3. SAFETY NOTES

TANNER rotary microtomes are provided with the following safety features:

**Hand wheel stop**

**Finger protection guard for knife- or blade-holder**

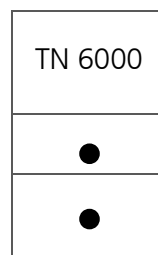

The institution which owns the unit and the persons working with the unit, servicing or repairing it have the responsibility for a hazard-free use.

### 3.1 HAND WHEEL STOP

Always use the finger protection guard with the knife-/blade holder and put hand wheel in stop position

- Before working with the knife or specimen
- Before changing the specimen
- During break time

The hand wheel can be stopped in any position. For this purpose move stop towards the centre.

For releasing the stop please turn the lever towards the outside again.

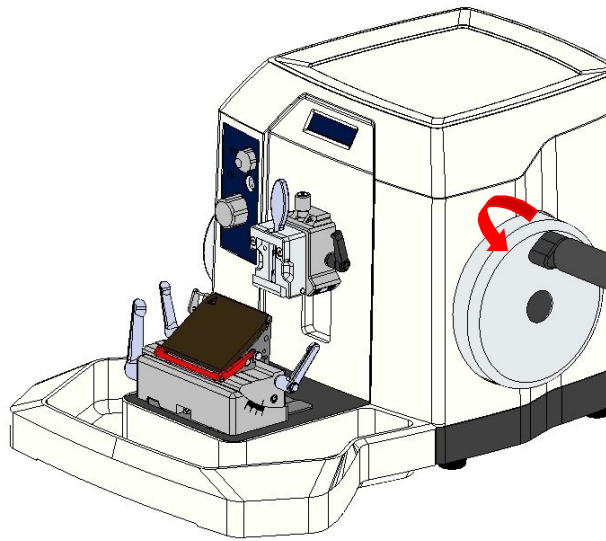

Activation of hand wheel stop.

### 3.2 FINGER PROTECTION GUARD

Use the finger protection guard always

- Before you start any work with the knife or specimen
- Before changing the specimen
- During work break

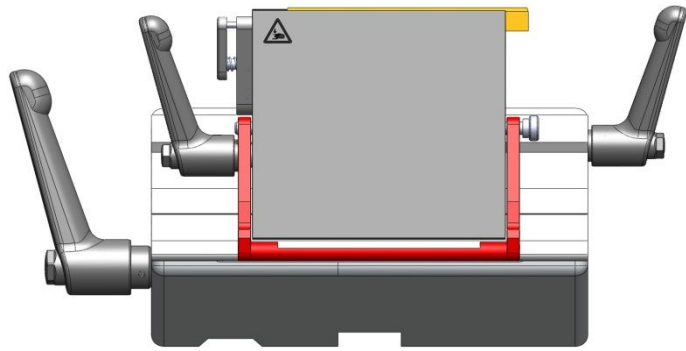

Finger protection guard released

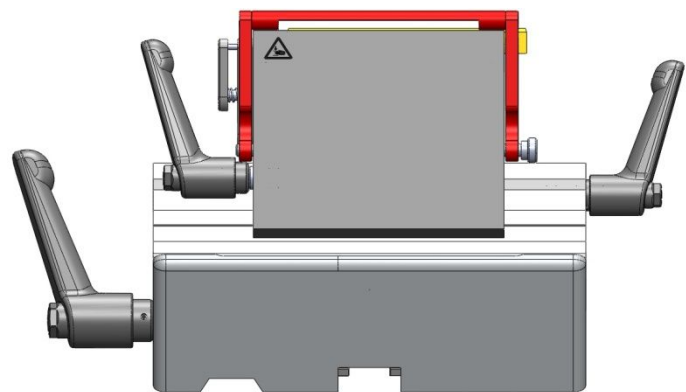

Finger protection guard activated



Please note that the finger protection guard may be engaged throughout processing (exchange of blade, lateral displacement, trimming, cutting), thereby increasing operation safety!



Do never move your fingers or hands above or behind the blade holder during operation of the microtome. For loading and unloading of the sample holders and exchange of disposable blades in the disposable blade holder, always activate the handwheel lock and activate the finger protection guard.

### 3.3 WORKING WITH KNIVES AND DISPOSABLE BLADES

Microtome knives and disposable blades have extremely sharp edges and this can lead to injuries.

Please be extremely careful when handling microtome knives and disposable blades.



Do not place microtome knives or disposable blades at unsecured areas.

Never position microtome knives or disposable blades with the sharp edge pointing upwards.

Store blades in a covered container. Use a container that has guides to hold the blades rigid.

Never try to catch a falling microtome knife.

Always insert the specimen first and then the microtome knife or disposable blade.

When applying the brake, ensure that it is tight. Most accidents occur when the brake slips and the operator's hand is drawn into the blade.

To avoid compression or knife marks, ensure that the blade is clean.

## 4. COMPONENTS

TANNER rotary microtomes are provided with the following standard components:

	TN 6000
<b>Basic instrument</b>	<b>manual</b>
<b>Object orientation</b>	●
<b>Universal-Cassette-Clamp with orientation</b> alternatively with another clamp as per request, e.g. Standard-Object-Clamp	●
<b>3-component-disposable-blade-holder</b> Applicable for low and high profile disposable blades	●
<b>Waste tray</b>	●
<b>1 box disposable blades (50 pcs.)</b>	●
<b>Operation manual</b>	●
<b>1x Allen key</b> For fixation of object orientation to microtome	●



## 5. SPECIFICATIONS

### General

Operating temperature range	+10 °C to +35 °C
Temperature range during storage	+5 °C to +55 °C
Relative humidity	max. 80% non condensing
Humidity during storage	< 8%
Operating temperature range	+10 °C to +35 °C
Section thickness setting range	0.5 – 60 µm
Section thickness selection	0.5 - 2 µm in 0.5-µm steps 2 - 10 µm in 1-µm steps 10 - 60 µm in 2-µm steps
Trimming thickness	10 µm, 20 µm, 30 µm, 40 µm
Specimen feed	28 mm (via coarse feed handwheel)
Vertical specimen stroke	60 mm
Maximum specimen size	50 x 50 mm
Knife holder basis - north-south axis	35 mm
Specimen retraction on return stroke	automatic
Specimen orientation, horizontal	8°
Specimen orientation, vertical	8°
Specimen orientation, z-axis	360°
Section counter	Strokes (optional)
Dimensions	
[width x depth x height]	480 mm x 610 mm x 350 mm
incl. handwheel and waste tray	
Weight without accessories	33 kg

## 6. UNPACKING AND INSTALLATION

### 6.1 UNPACKING THE INSTRUMENT

Remove the upper wooden cover. Remove the upper supporting foams.

Lift the instrument out of the wooden transportation case.

Lift the instrument by holding it by the base plate and the recessed grip on the back and lift it out of the formed cushion.

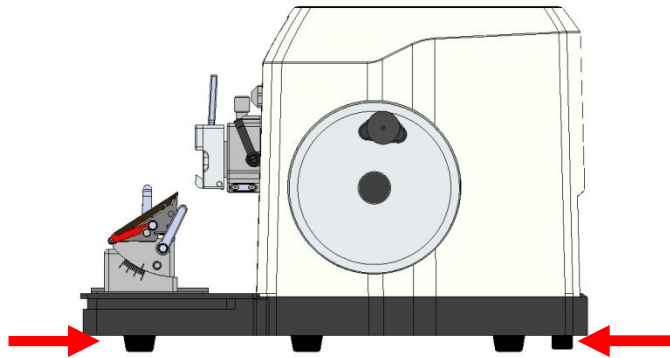

Do not transport the instrument by holding it on the hand wheel shaft, the object head, the cover or the tray.

For repacking use the original cases. Keep the packing material.

Place the instrument onto the selected bench.

### 6.2 INSTALLATION

The unit should be positioned onto a plane, vibration-free surface.

Assure convenient and unobstructed access to the hand wheel.

Before use remove the transport security underneath the specimen head.

## 7. OPERATION OF TN 6000 MANUAL

### 7.1 INSERTION OF SPECIMEN IN STANDARD OBJECT CLAMP

Activate hand wheel lock.

Activate finger protection guard.

Loosen object fixation by turning the fixation screw counter clockwise.

Insert/Remove object.

Tighten object fixation by turning the fixation screw clockwise.

Release finger protection guard and hand wheel lock for cutting.

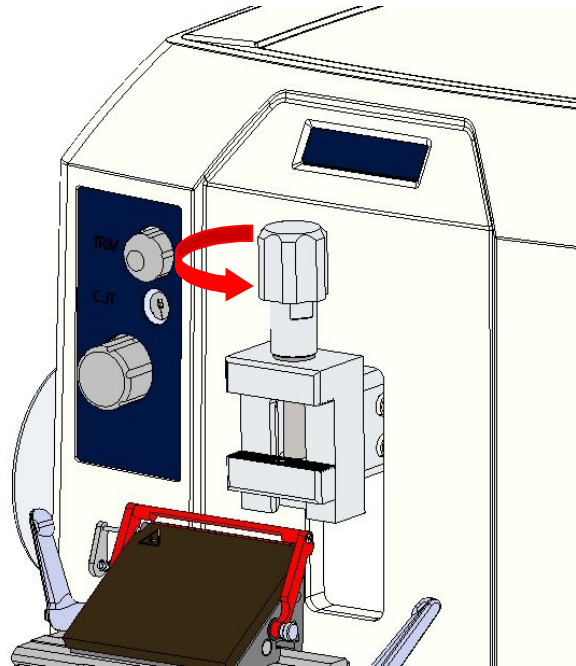

Loosening of object fixation and insertion of new object

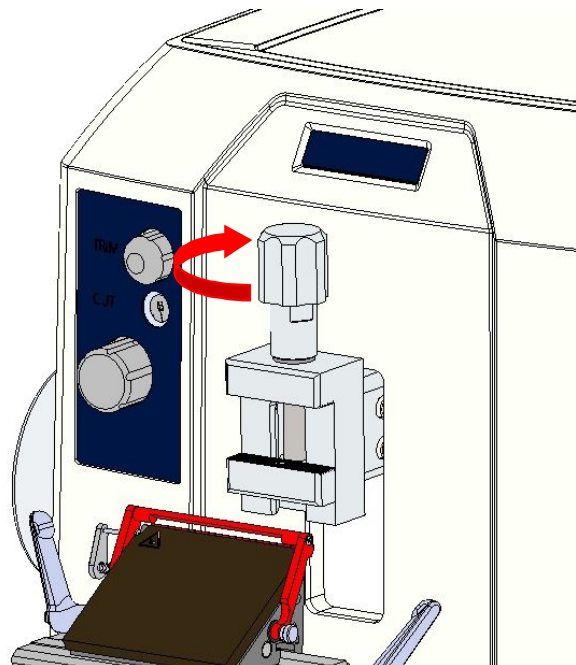

Fastening of object fixation

## 7.2 INSERTION OF SPECIMEN IN UNIVERSAL CASSETTE CLAMP

Turn hand wheel to its highest position and activate the hand wheel lock.

Activate finger protection guard.

Open cassette fixation by pulling the fixation lever.

Insert/Remove cassette.

Object fixation will go back into fixation position automatically.

Release finger protection guard and hand wheel lock for cutting.

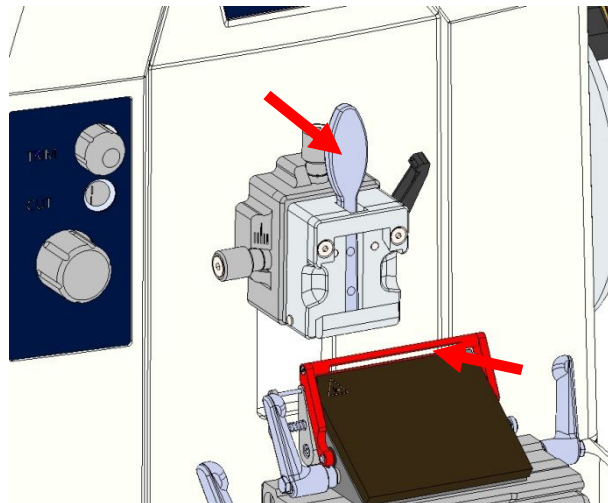

Opening of cassette fixation and insertion of new cassette

### 7.3 SPECIMEN ORIENTATION ADJUSTMENT

Turn hand wheel to its highest position and activate the hand wheel stop.

For orientation of the specimen, open the fixing lever on the right side of the orientation.

For upward and downward orientation use the upper orientation wheel.

For orientation to the left and right use the left orientation wheel.

Close the orientation fixing lever.

Release hand wheel lock for cutting.

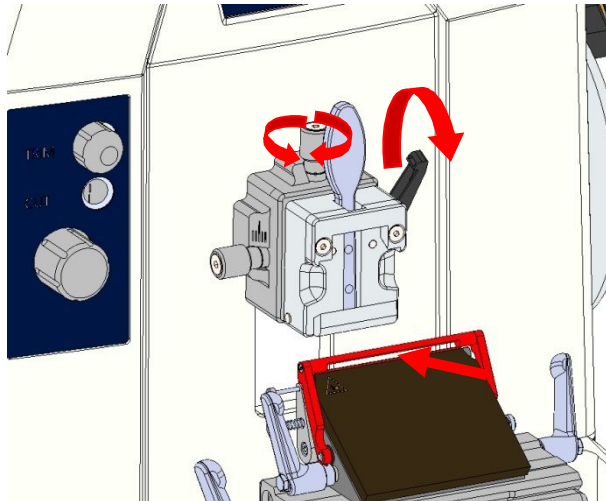

Opening of orientation fixation lever and orientation of object holder upwards and downwards

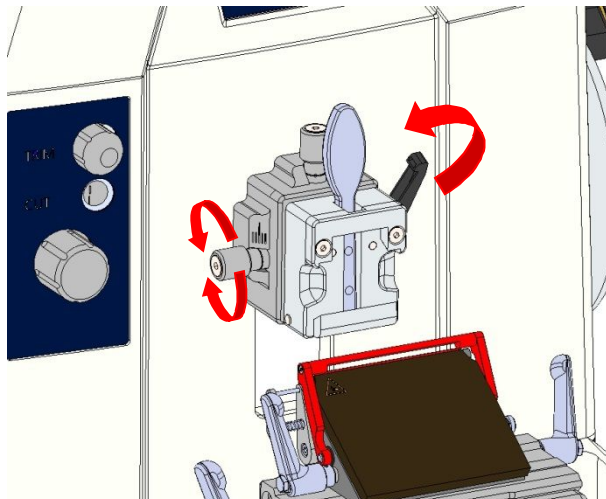

Orientation of object holder to the left and right and fixation of orientation

## 7.4 INSERTION OF KNIFE

Activate hand wheel lock.

Remove finger protection guard on the right side of the knife holder.

Loosen the knife fixation by turning the two black screws counter clockwise.

Insert knife from the right side.

Tighten the knife fixation by turning the two black screws clockwise.

Adjust knife height by turning the wheels on the left and right side of the knife holder base.

Install finger protection guard on the right side of the knife holder.

Release hand wheel lock for cutting.

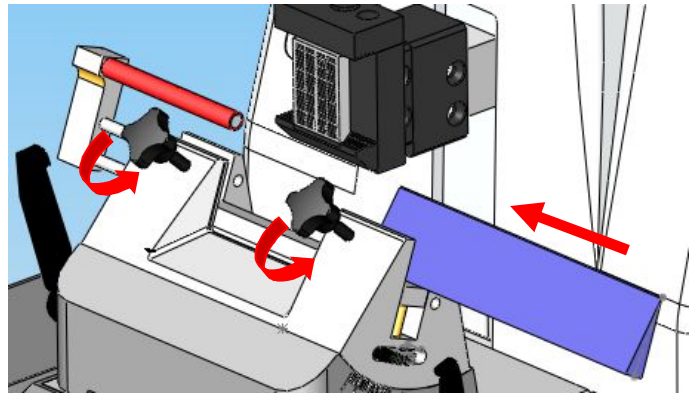

Loosening of knife fixation and insertion of new knife

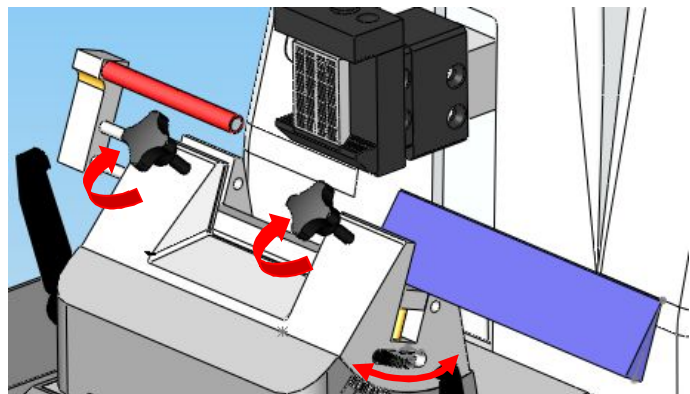

Fixation and height adjustment of knife

## 7.5 INSERTION AND ORIENTATION OF DISPOSABLE BLADE

Activate hand wheel lock.

Remove finger protection guard.

Loosen the blade fixation by turning the left lever clockwise.

Insert blade from one side.

Tighten the blade fixation by turning the left lever counter clockwise.

Release hand wheel lock for cutting.

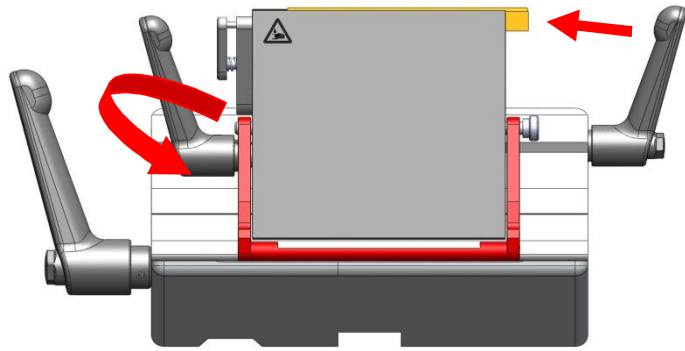

Loosening of blade fixation and insertion of new blade.

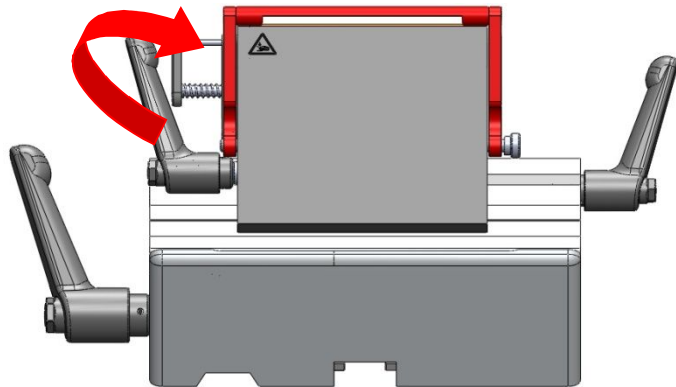

Fixation of blade.

## Horizontal orientation

For adjustment of cutting area of the blade, loosen the blade holder fixation by turning the right lever on the blade holder base counter clockwise.

Set new cutting area by moving the blade holder to the left or to the right.

Tighten the blade holder fixation by turning the right lever on the blade holder base clockwise.

Release hand wheel lock for cutting.

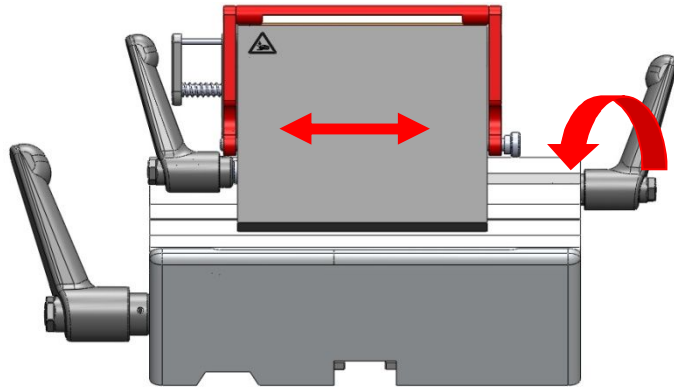

Loosening of blade holder fixation and horizontal orientation of blade holder

## Cutting Angle

For adjusting the cutting angle of the blade, loosen the blade holder fixation by turning the indicated screw with an allen key (size 6) counter clockwise.

Set new angle for cutting by manually tilting the blade holder. A tilt towards the object holder increases the cutting angle, a tilt away from the object holder decreases the cutting angle.

Tighten the blade holder fixation by turning the indicated screw with an allen key (size 6) clockwise.

Release hand wheel lock for cutting.

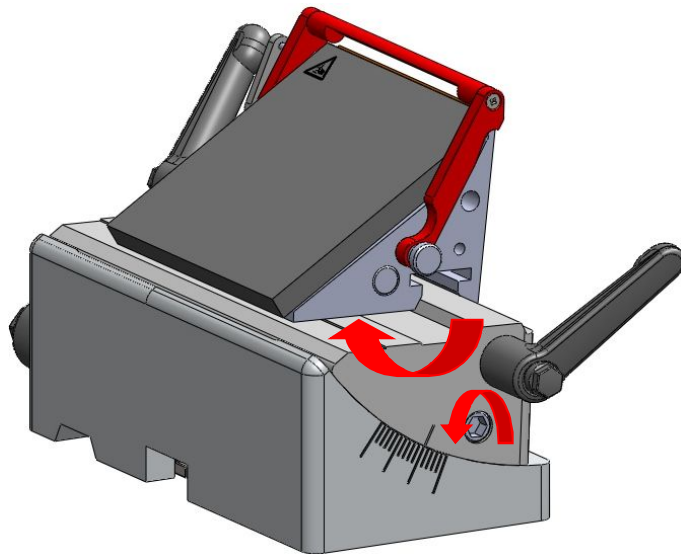

Loosening of blade holder fixation and adjusting new cutting angle



## Adjusting the sledge clamping

How to:

1. Remove the screw with allen key size 2,5 (pos. 1)
2. Removing washers makes clamping tighter & Adding washers loosens clamping
3. Tighten the screw (pos. 1) and test the clamping by assembling the blade holder

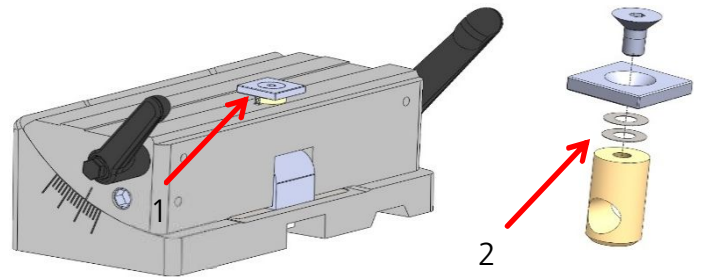

## Adjusting the blade clamping

How to:

1. Remove away the blade clamping plate (pos. 1)
2. Take the brass plunger (pos. 2) and add / remove one of the supplied adjustment washers (pos. 3) adding washers = clamping tighter removing washers = loosens clamping
3. Tighten the screw (pos. 4) and test the clamping by assembling the blade holder

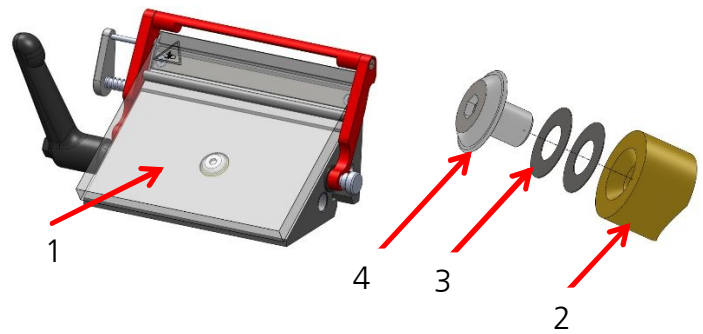

## Modification from low to high blades

Before any manipulation of the blade holder remove the blade!

The first picture shows the low profile configuration, underneath the low profile configuration without the blade and the third picture shows the high profile configuration.

To change from low profile to high profile configuration the two screws (pos. 1) have to be unscrewed with a PH0 screwdriver and the adapter strip (pos. 2) needs to be removed.

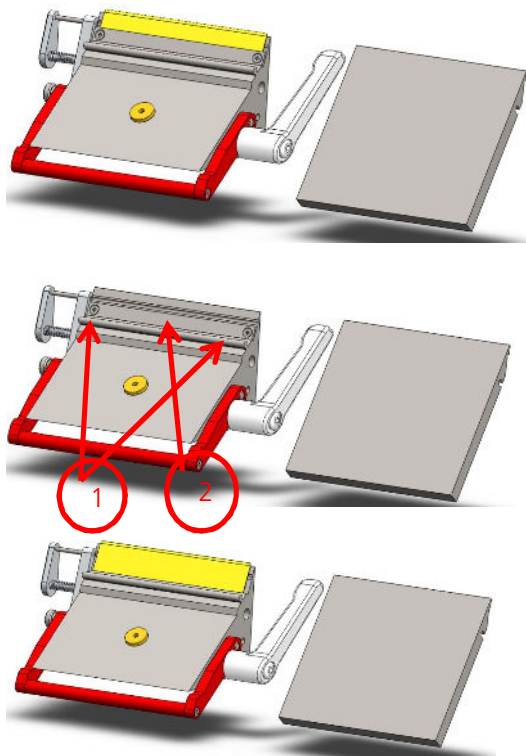

## Changing the lever to the other side

How to:

1. Loosen the screw (located on bottom side of lateral sledge) with Allen key (see pic., marked with red circle no. 1)
2. Take the lever out of the sledge and put it into the bored hole from the other side
3. Tighten the screw at the other side (marked with red circle no. 2).

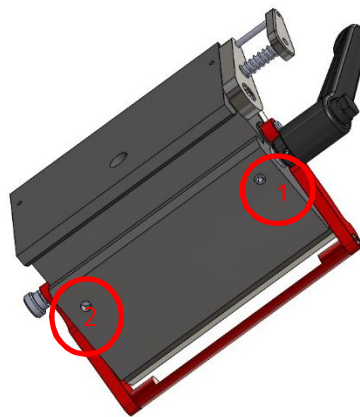

## Changing the lever to the other side

How to:

1. Loosen the screws (2x) (located on bottom side of middle part) with Allen key (see pic., marked with red circle no. 1)

2. Take the lever out of the sledge and put it into the bored hole from the other side

3. Tighten the screws at the other side (marked with red circle no. 2).

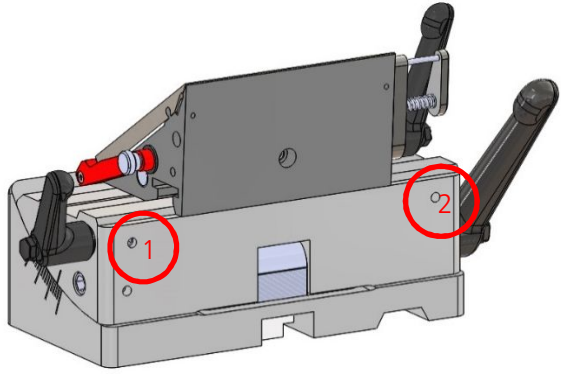

## 7.6 APPROACH TO SPECIMEN

Turn the handwheel to the highest position and activate the handwheel lock. Loosen the knife or blade holder base by turning the left lever counter clockwise.

Tighten the knife or blade holder base by turning the left lever clockwise.

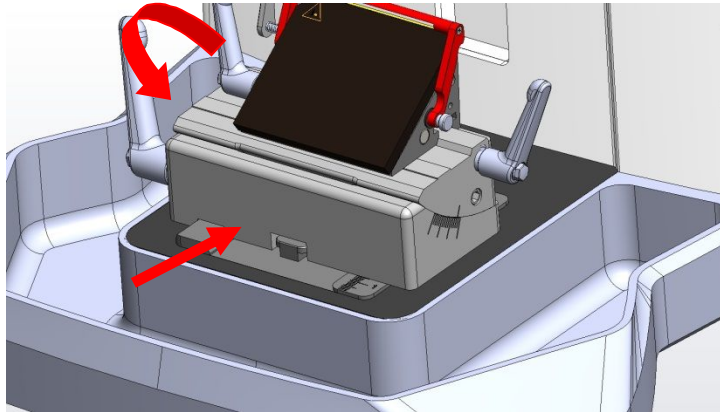

Loosening of knife or blade holder base fixation and movement towards specimen

Move knife or blade holder base towards specimen.

There is a scale on the right side of the microtome base plate. This enables faster and better positioning of the knife holder at the specimen if various combinations of standard specimens and specimen holders are used.

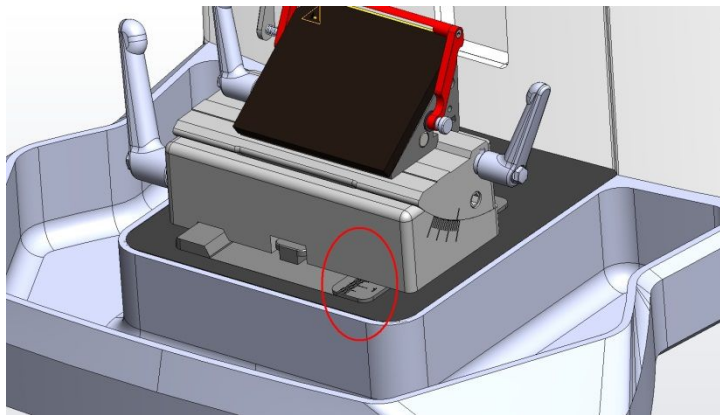

Fix the new setting by turning the lever on the left side of the knife holder base clockwise (see figure).

Loosen the handwheel lock to cut the sample

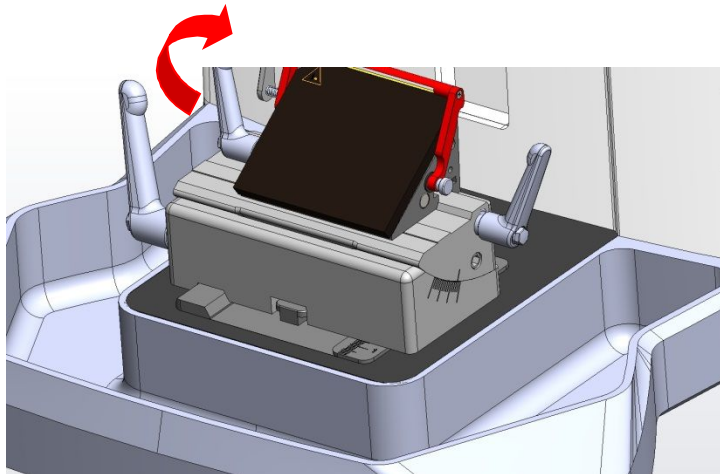

Fixation of knife holder base

## 7.7 COARSE ADVANCE [applicable only to TN 6000 MANUAL]

Turn hand wheel on the left-hand side of the instrument to move the specimen towards the knife or blade.

At the end positions a sound signal will be heard, do not go further in the same direction.

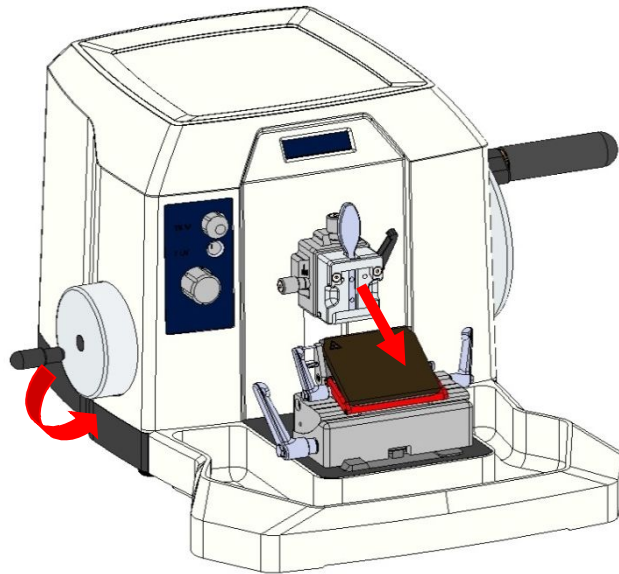

Coarse advance of specimen

## 7.8 MANUAL CUTTING

Release hand wheel stop.

For cutting turn the hand wheel on the right side of the instrument clockwise.

A counter clockwise movement of the hand wheel will also result in cutting and incremental advance of the specimen.

Optionally set new cutting angle as described in section 7.5 (OPERATION OF TN 6000 MANUAL).

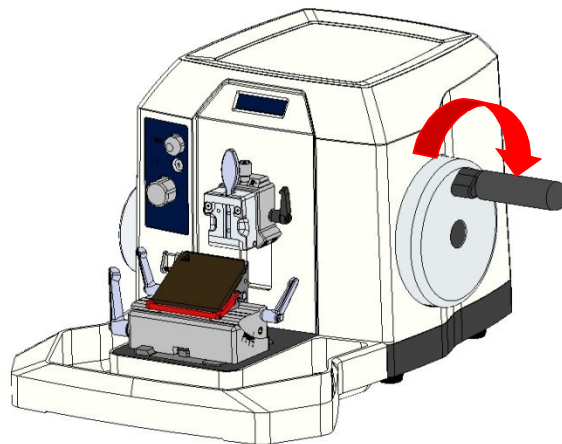

Cutting of specimen

For trimming of specimen, select the thickness with the upper knob on the left front side of the instrument (either 10, 20, 30 or 40  $\mu\text{m}$ ) and press knob during cutting.

Select cutting thickness by turning the lower knob on the left front side of the instrument. The selected cutting thickness is displayed above the knob.

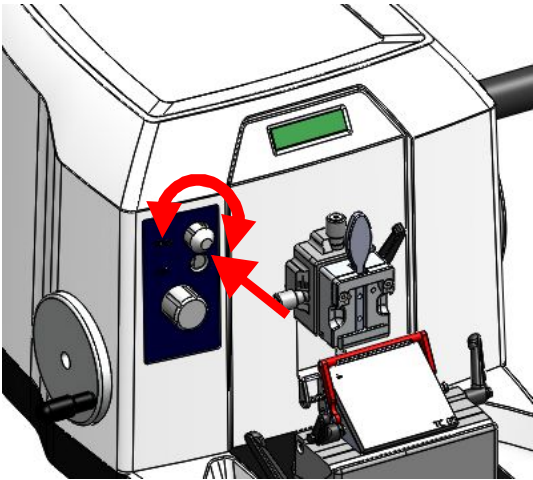

Selection of trimming thickness and trimming

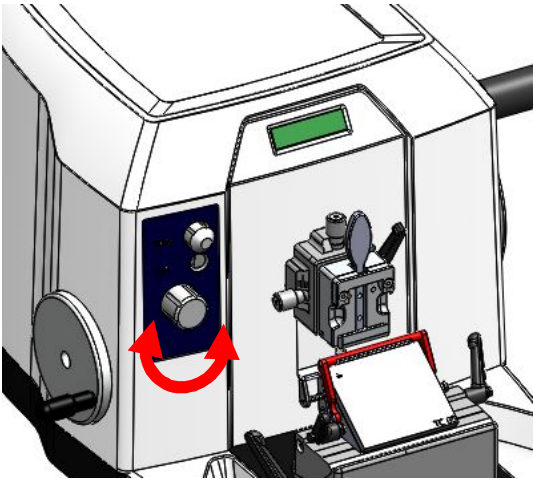

Selection of cutting thickness

## 8. CLEANING AND MAINTENANCE

### 8.1 CLEANING

The recommended frequency of cleaning the microtome depends on how frequently the instrument is used.



Wear protective clothing and disposable gloves according to Good Laboratory Practices.

Please take note of the safety aspects of the instrument.

Do not use acetone or xylene for cleaning the unit. Only use alcoholic media.

The hood should be cleaned with commercially available plastic cleaner. Do not use alcoholic or organic solvents to clean the hood.

Never spray or use cleaning medium directly onto the touch panels.

### 8.2 RECOMMENDED MAINTENANCE AND SERVICE SCHEDULE

**Daily** Remove section waste from the waste tray after every day of usage.

**Weekly** Cleaning of blade holder

**Yearly** Complete Service (performed by authorized TANNER service technician)

- Check of all functions
- Lubricating of movable parts
- Check of driving system
- Complete cleaning

## 9. SERVICE

Internal components should only be serviced by technicians authorized by TANNER.

If technical service or spare parts are necessary, please contact your local Tanner Scientific distributor. Please have the following information available:

- Complete contact details
- Type of instrument and serial number
- Place of instrument and name of user
- Purpose of service call
- Delivery date of the unit

If it is necessary to return the instrument, it must be cleaned and disinfected before delivery. It must be returned in its original packing.

If the instrument or parts thereof are sent back in a dirty or non-disinfected condition, TANNER reserves the right to return the parts to the debit of the customer.



## 10. Optional accessories

	TN 6000
<b>3-component disposable blade holder</b> adapted for low and high profile disposable blades	●
<b>3-component blade holder (TC65)</b> adapted for tungsten carbide blades (hard metal blades)	●
<b>Blade holder for 3-component blade holder (tungsten carbide blades)</b> Fitting to 3-component blade holder	●
<b>Standard Knife Holder</b>	●
<b>Knife/blade holder basis</b>	●
<b>Object Orientation</b>	●
<b>QuickLoad-Cassette-Clamp, orientable</b>	●
<b>Standard Object clamp, orientable</b>	●
<b>Standard Object clamp, fixed</b>	●
<b>Super-Mega-Cassette Clamp, orientable</b>	●
<b>Super-Mega-Cassette Clamp, fixed</b>	●
<b>Foil clamp</b>	●

	TN 6000
<b>Prism Set</b>	●
<b>Magnifier with illumination</b>	●
<b>Section counter</b>	●
<b>Disposable blade (low profile; 50 pcs.)</b>	●
<b>Disposable blade (high profile; 50 pcs.)</b>	●
<b>Disposable blade LPS (low profile; 50 pcs.)</b>	●
<b>Disposable blade LPH (low profile; 50 pcs.)</b>	●
<b>Disposable blade HPS (high profile; 50 pcs.)</b>	●
<b>Tungsten carbide blades (1 pcs.)</b>	●
<b>Microtome knife</b> Profile: C or D Length: 10 to 40 cm	●

## **11. WARRANTY**

Tanner Scientific guarantees that the product delivered has been subjected to a comprehensive quality control procedure, and that the product is faultless and complies with all technical specifications and/or agreed characteristics warranted.

Tanner Scientific guarantees that the instrument is manufactured under an ISO 9001 quality management system.

Unauthorized modification or repair by third party persons will void the warranty.

Only original TANNER spare parts must be used.

Guarantee claims can be put forward only if the instrument is used according to this manual and for the purpose described.

Mistakes and errors which occur because of improper use cannot be accepted.

## **12. DISPOSAL**

The instrument or parts of the instrument must be disposed of according to existing local applicable regulations.





**Tanner Scientific**

12210 Rangeland Parkway

34211 Bradenton FL / US

Tel. (888) 708-5233

[sales@tannerscientific.com](mailto:sales@tannerscientific.com)

<http://www.tannerscientific.com>